

TUDORS

First Avenue, West Molesey, Surrey, KT8 2QN



Price £ 375,000 Freehold

TUDORS are pleased to offer for sale this nicely presented two bedroom mid terrace home which has the benefit of being offered to the market with NO ONWARD CHAIN. The property has potential to be extended on the ground floor (S.T.P.P) – other examples can be seen in the road. Situated close to local shops, primary schools and bus routes leading to East Molesey, Hampton Court (with Palace, restaurants & station – zone 6), Walton-on-Thames, Hersham and Kingston (offering comprehensive shopping).

The accommodation comprises of; an entrance hallway, a living room with decorative fireplace and a kitchen/breakfast room with deep storage cupboard. The kitchen has many eye/base level units/cupboards with stainless steel sink overlooking the rear garden. Stairs from the hallway lead to a landing with access to two bedrooms and a bathroom with white suite.

Externally the rear garden is mainly laid to lawn with patio and shingle stone areas. There is also a timber built shed and mature border plants. To the front there is smart block paved driveway providing off road parking. Other benefits; include double-glazing, gas central heating and external elevation insulation (EPC rating: D) Elmbridge Borough Council band C = £1,919.00

PROPERTY DETAILS

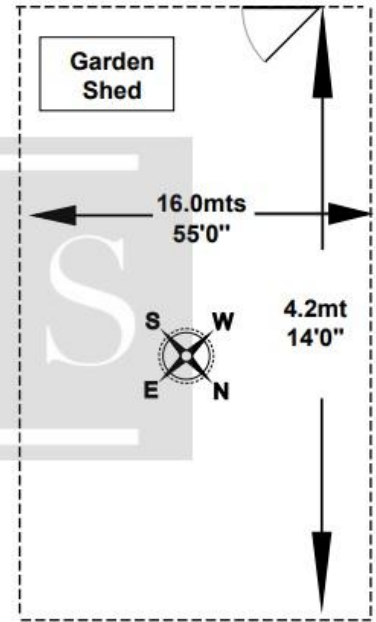
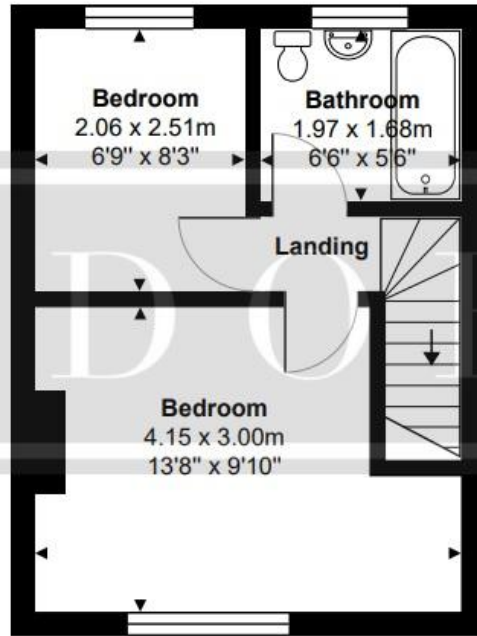
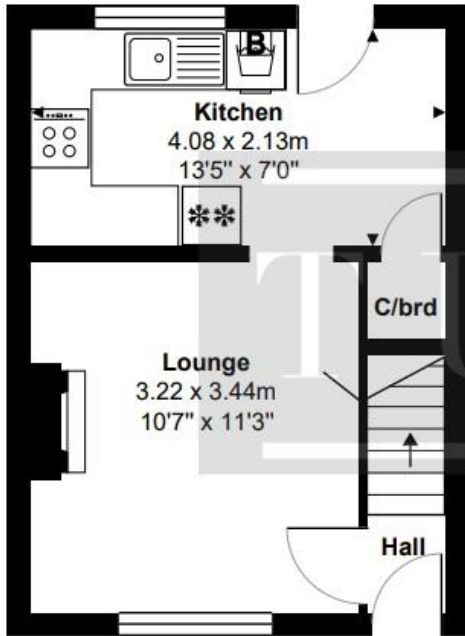

Ground Floor

First Floor

Garden

Total Area: 47.4 m² ... 510 ft²

All measurements are approximate and for display purposes only.

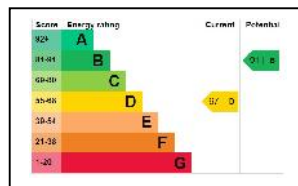

PROPERTY DETAILS



PROPERTY DETAILS

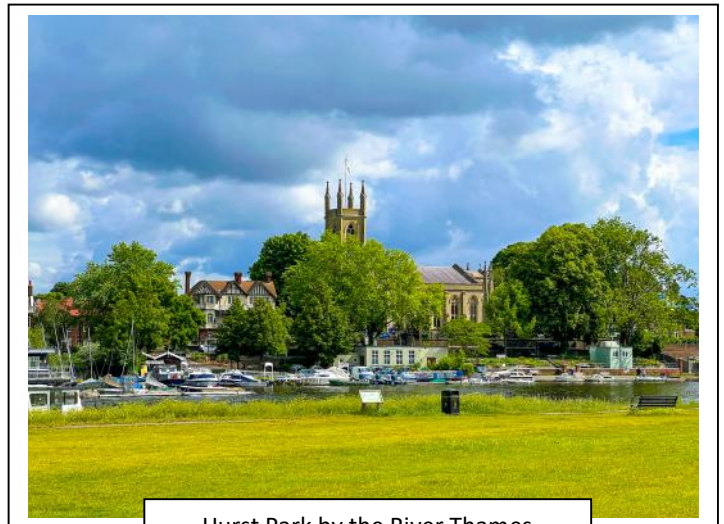

Hurst Park by the River Thames



Hurst Park by the River Thames



Hurst Park by the River Thames

Please Note: These sales particulars are only intended as a guide and do not form part of any contract – For fixture & fittings, please consult your conveyancer who will have a list of which items will be staying. All the measurements stated are approximate only. Any internal photographs are intended as a guide only and it should not be assumed that any of the furniture is included in any sale. Where shown, details of lease, ground rent & service charge are provided by the vendor & their accuracy cannot be guaranteed as the information has not been verified. Due to the enforcement of the property mis-description act, effective from April 1993, purchasers should make their own enquiries and ascertain that all services and appliances referred to in this sales particulars are in working order - where appliances, including central heating, are mentioned, it cannot be assumed that they are included & are in working order as they have not been tested.