

TUDORS

Buckingham Avenue, West Molesey, Surrey, KT8 1TG



Price £ 575,000 Freehold

Tudors are pleased to offer for sale this impressive four bedroom end of terrace 'Wates' town house which is ideally positioned enjoying wonderful views across the Hurst Park development. Rare to the market, this is the first time the property has been listed by the vendors since first built circa 1965 – owned by the current vendors for 58 years.

Many original features including parquet flooring, original 'Wates' decoration with kitchen units and cupboards and original 'Wates' bathroom.

The vendors have enjoyed living at the property and the Hurst Park development with all that it offers. Offered to the market with **NO ONWARD CHAIN.**

Of particular mention is the larger patio front garden which has lots of potential to extend S.T.P.P – Other examples can be seen in the road. The property has the added benefit of extra side windows allowing an abundance of light that many other townhouses in the development do not have, the wonderful larger front patio garden and a garage in a nearby block. Located close to primary schools, Tesco supermarket with Post Office, the River Thames with its towpath leading to Hurst Meadows and Hampton Court with its Palace, restaurants, boutiques, cafes and train station – ideal for the commuter to Waterloo, Oyster zone 6 and also Bushy Park – With over 1000 acres, East Molesey cricket club, Molesey Rowing club, Molesey sailing club, Hurst swimming pool and the Pavillion sports club are also nearby. There are also bus routes connecting East Molesey, Walton on Thames, Hersham and Kingston (with comprehensive shopping).

The property comprises; an entrance hallway with storage cupboards and parquet flooring, a downstairs cloakroom and a utility room with door leading to the rear garden. There is a front reception dining room with sliding patio doors opening to a southerly facing patio garden. There is also a kitchen/breakfast room on the ground floor with original eye/base level units/cupboards with work top area.

Stairs from the hallway lead up to a landing; with access to bedroom four, which is a double room with a built in wardrobe and original vanity sink. The landing also leads to a bright and airy, comfortable large living room which enjoys wonderful views over Hurst Park. Stairs from the living room lead to a further landing with access to three bedrooms (two with built in wardrobes and original decoration) and a bathroom with matching suite.

Externally there is a mature rear garden with many plants and shrubs and a rear access gate. To the front there is a mature garden with pathway leading to the front door. Other benefits include; some double-glazed windows and doors. (EPC rating:) Elmbridge Borough Council = Band E: £2,639.00

TUDORS
61 WALTON RD, E.MOLESEY, SY, KT8 ODP

T. 0208 224 4020
www.tudorandco.co.uk

PROPERTY DETAILS

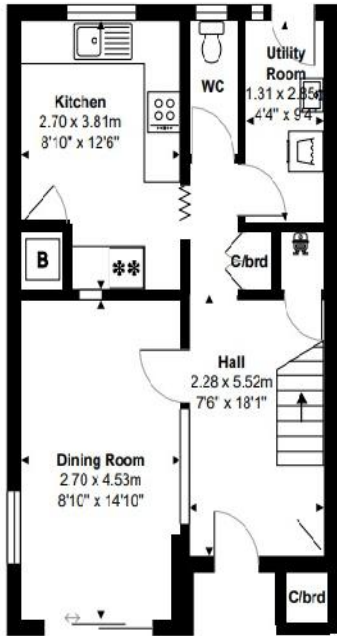

Ground Floor

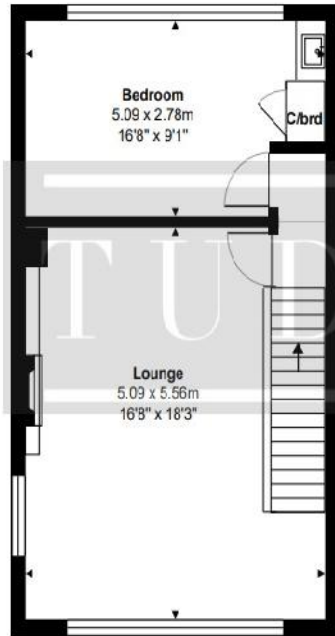

First Floor

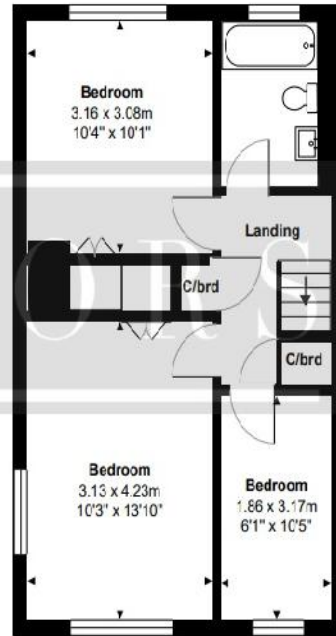

Second Floor

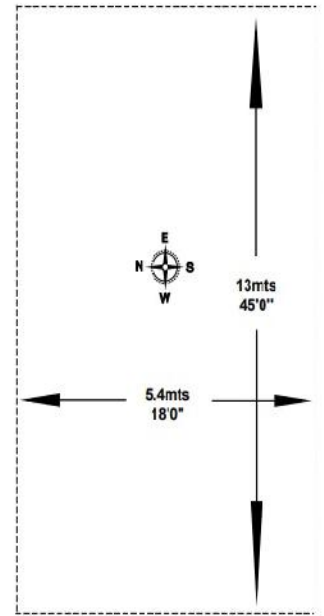

Garden

Total Area: 128.5 m² ... 1383 ft²

All measurements are approximate and for display purposes only.

Please Note: These sales particulars are only intended as a guide and do not form part of any contract – For fixture & fittings, please consult your conveyancer who will have a list of which items will be staying. All the measurements stated are approximate only. Any internal photographs are intended as a guide only and it should not be assumed that any of the furniture is included in any sale. Where shown, details of lease, ground rent & service charge are provided by the vendor & their accuracy cannot be guaranteed as the information has not been verified. Due to the enforcement of the property mis-description act, effective from April 1993, purchasers should make their own enquiries and ascertain that all services and appliances referred to in this sales particulars are in working order - where appliances, including central heating, are mentioned, it cannot be assumed that they are included & are in working order as they have not been tested.

PROPERTY DETAILS



The property enjoys original Parquet wood flooring



The property is ideally positioned to enjoy wonderful light and views over Hurst Park development from the middle floor



PROPERTY DETAILS



PROPERTY DETAILS



The property is ideally positioned to enjoy wonderful light and views over Hurst Park development from the top floor

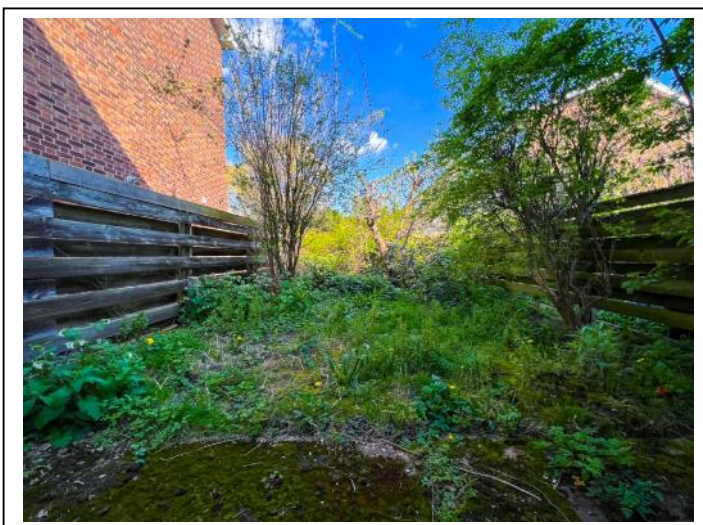

PROPERTY DETAILS

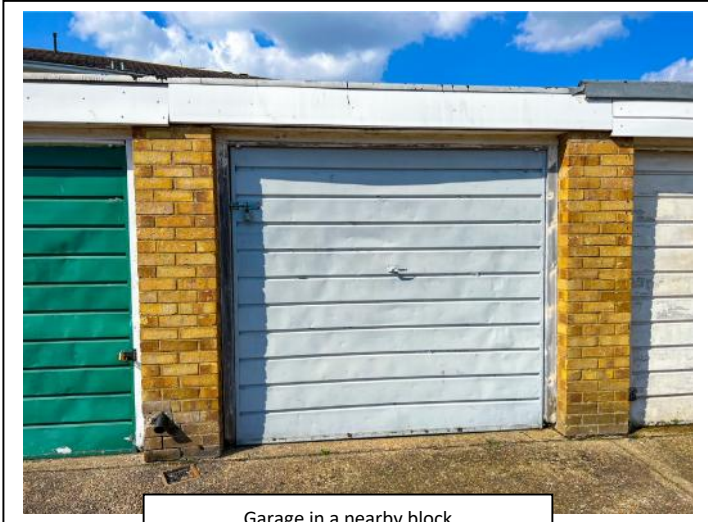

Garage in a nearby block

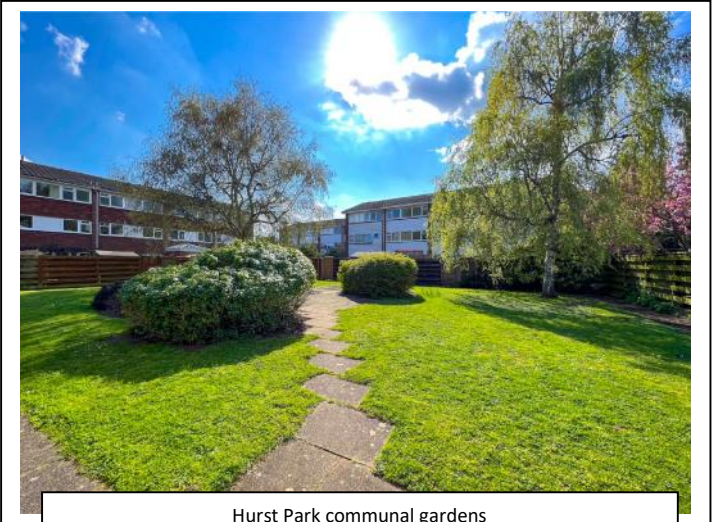

Hurst Park communal gardens

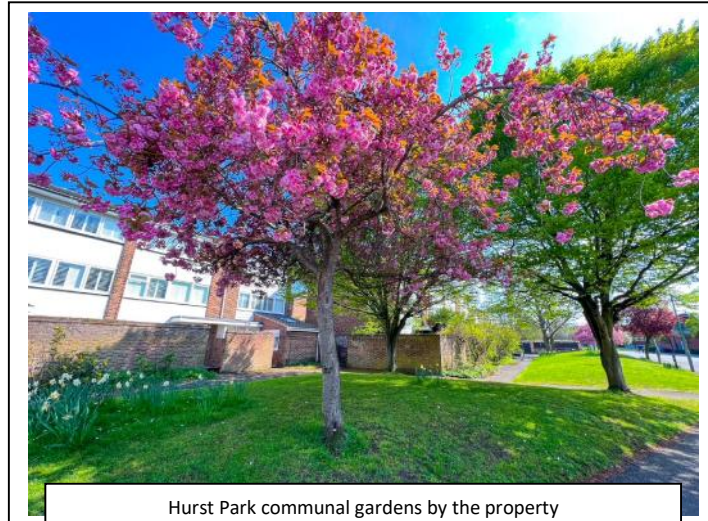

Hurst Park communal gardens by the property

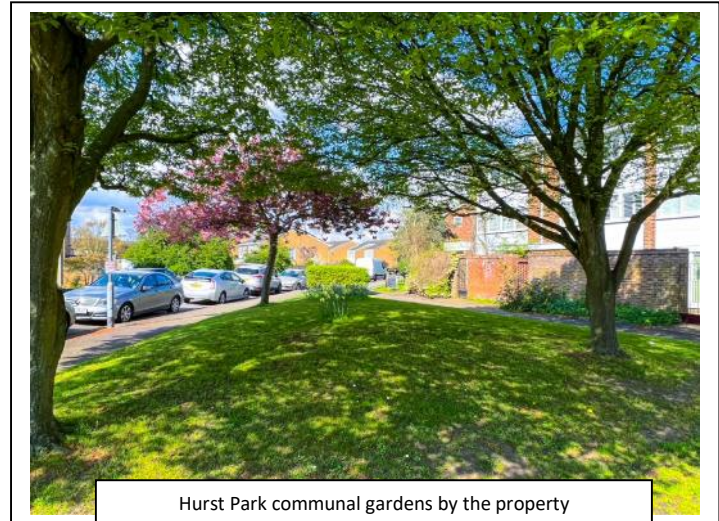

Hurst Park communal gardens by the property



PROPERTY DETAILS



The property is within yards of Hurst Park Meadows (Ideal for walking) with wonderful views St. Mary's Church in Hampton



The property is with yards of the River Thames towpath leading to Hampton Court Place + train station



The property is with yards of the River Thames towpath leading to Hampton Court Place + train station



The property is with yards of Hurst Meadows recreation fields